

ULTRAPOINT™ AIR BULK

800 ML BULK DISPENSER



FEATURES

- Easily replaceable barrel and washer
- Choice of nozzles for pointing and grouting
- 6.8 bar (100 psi) regulator
- Return air feature

BENEFITS

- Greater efficiency neater, cleaner with less waste
- Mortar mixing paddle and two nozzles supplied
- Fitted as standard – others are available
- Plunger rods are automatically ready reloading

APPLICATIONS

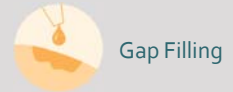

PRODUCT BY RANGE



Ultrapoint Air

THE ULTRAPoint BULK 1-COMPONENT PNEUMATIC DISPENSER COMES WITH A CHOICE OF NOZZLES FOR POINTING AND GROUTING FOR SPECIALIST MASONRY REPAIR AND HIGH VOLUME DISPENSING.

SPECIFICATIONS

- Weight: 0.99 kg / 2.2 lbs
- Frame Length: 358 mm / 18.27 in
- Maximum Thrust: 1.45 kN
- Maximum Pneumatic Pressure: 6.8 bar (100 psi)
- Handle Material: Aluminum
- Frame Material: Epoxy Coated Steel
- Barrel Material: Anodized Aluminum
- Bulk Material Feed: 800 mL (35.2 oz)
- Standard Color: Black/Blue
- Customized versions on demand

DIMENSIONS

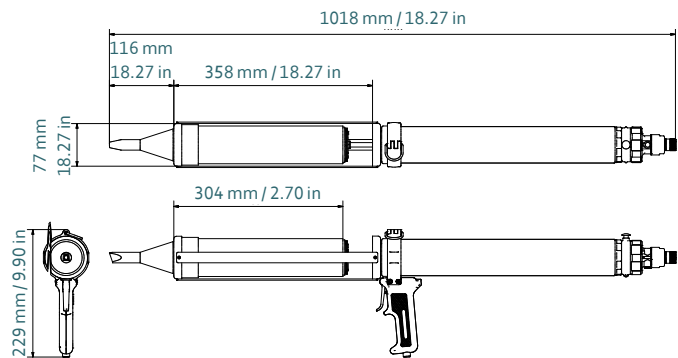

| Product | Article number | Packaging |
|---------------------|----------------|-----------|
| DP1C 800-bu-145-101 | 161843 | 1 per Box |

MATCHING MIXPAC™ CARTRIDGES

COMPATIBLE OTHER



CONVERSION KITS

MATCHING ACCESSORIES

Grouting/pointing nozzle, dispenser tube on pages 98-102.