

# TS493 X / TS493 XT

## 600 ML CARTRIDGE DISPENSER

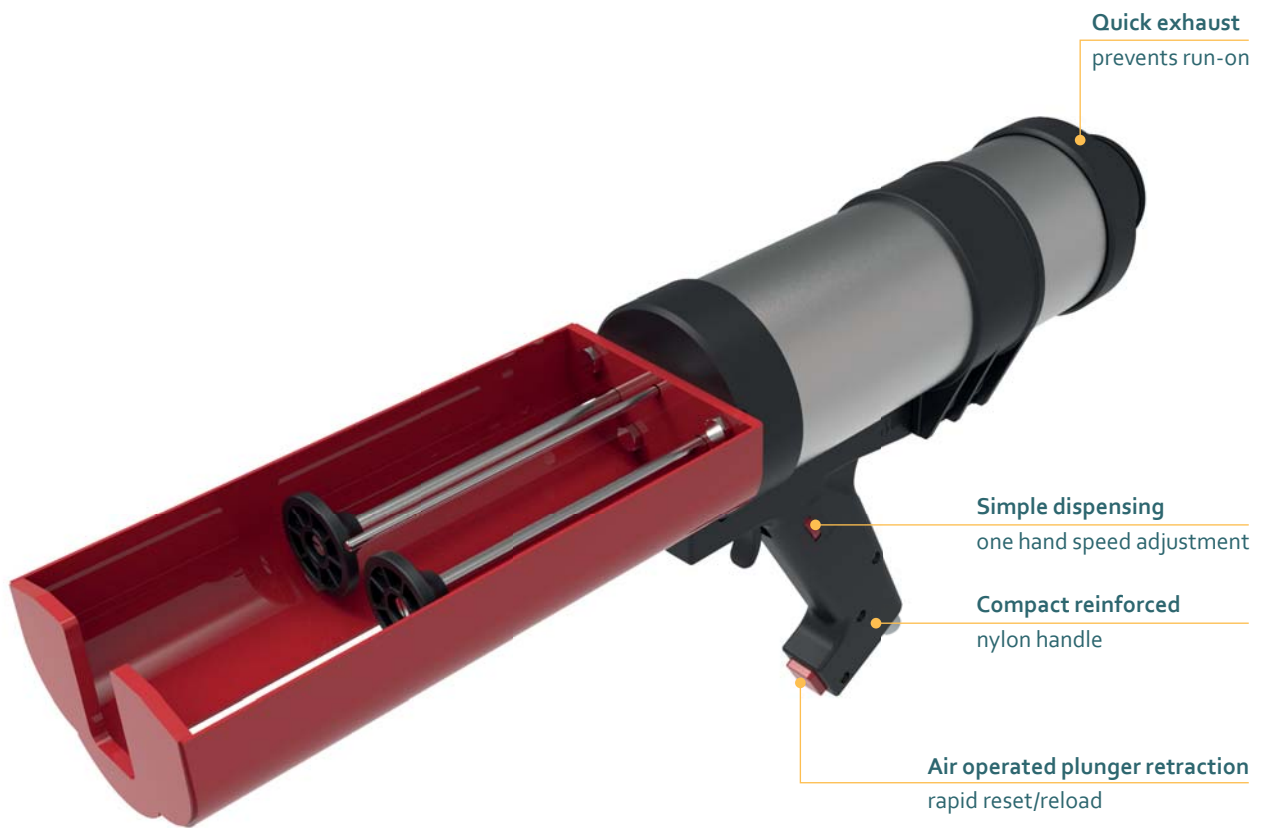

Model shown: TS493 X(T) 600 mL

### FEATURES

- Air operated plunger retraction
- One hand pressure adjustment
- Anti-drip function
- Long life technology
- Customization possible

### BENEFITS

- Quick cartridge exchange
- Simple dispensing speed adjustment
- Clean application
- Precise working
- Customer labelling

### APPLICATIONS



### PRODUCT BY RANGE



# THE TS493 X(T) 2-COMPONENT PNEUMATIC DISPENSER ANTI-DRIP FUNCTION MAKES FOR EASY AND CLEAN DISPENSING. IN ADDITION, THE AIR OPERATED PLUNGER RETRACTION OFFERS RAPID RESET AND RELOAD.

## SPECIFICATIONS

- Lightweight: 2.6 kg / 5.6 lbs
- Cartridge Holder Length: 235 mm / 9.3 in
- Maximum Thrust: 4 kN
- Maximum Pneumatic Pressure: 8 bar / 116 psi
- Air Consumption: 40 litres/min
- Handle Material: Reinforced Nylon
- Cartridge Holder Material: Aluminum
- Frame Material: Steel
- Cartridge Capacity: 600 mL (21.1 oz)
- Cartridge Ratio: 1:1
- Viscosity: Medium
- Standard Color: Black/Red
- Customized versions on demand

## DIMENSIONS

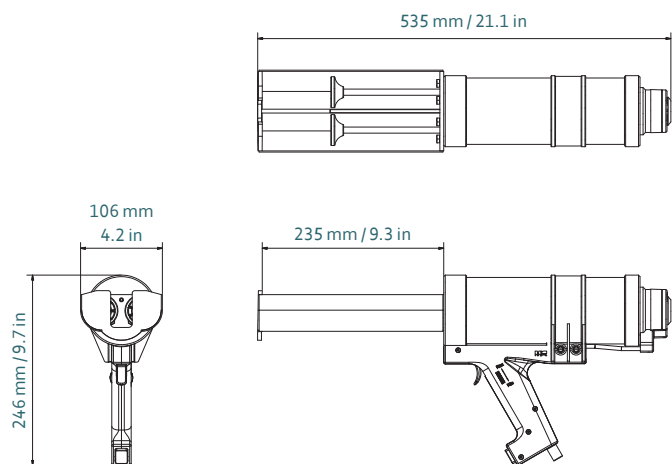

Part number	Article number	Packaging
DP2K 600-01-400-201	151790 TS493 X (620 mL)	1 per Box
DP2K 600-01-400-401	152883 TS493 XT (600 mL)	1 per Box

## MATCHING MIXPAC™ CARTRIDGES

## COMPATIBLE SIDE-BY-SIDE CARTRIDGES

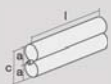

**Plastic Cartridge**  
620 mL (2 x 310 mL) / 1:1 PP

1:1	mm	inch
l	217.0	8.54
a	Ø 48.0	Ø 1.89
c	95.5	3.76

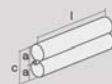

**Plastic Cartridge**  
600 mL / 1:1 PP

1:1	mm	inch
l	215.0	8.46
a	Ø 49.0	Ø 1.93
c	99.0	3.9

## CONVERSION KITS

## MATCHING ACCESSORIES