

TS483 XM

400 ML CARTRIDGE DISPENSER



Model shown: TS483 XM 400 mL

FEATURES

- Air operated plunger retraction
- One hand pressure adjustment
- Anti-drip function
- Long life technology
- Customization possible

BENEFITS

- Quick cartridge exchange
- Simple dispensing speed adjustment
- Clean application
- Precise working
- Customer labelling

APPLICATIONS



PRODUCT BY RANGE



THE TS483 XM IS A 2-COMPONENT PNEUMATIC DISPENSER DESIGNED FOR USE WITH MEDIUM TO HIGH VISCOSITY SEALANTS AND ADHESIVES. A ONE-HANDED PRESSURE ADJUSTMENT ALLOWS FOR SIMPLE EFFECTIVE OPERATION.

SPECIFICATIONS

- Lightweight: 2.6 kg / 5.6 lbs
- Cartridge Holder Length: 203 mm / 8.0 in
- Maximum Thrust: 4 kN
- Maximum Pneumatic Pressure: 8 bar / 116 psi
- Air Consumption: 40 litres/min
- Handle Material: Reinforced Nylon
- Cartridge Holder Material: Aluminum
- Frame Material: Steel
- Cartridge Capacity: 400 mL (14.1 oz)
- Cartridge Ratio: 1:1
- Viscosity: Medium/High
- Standard Color: Black/Red
- Customized versions on demand

DIMENSIONS

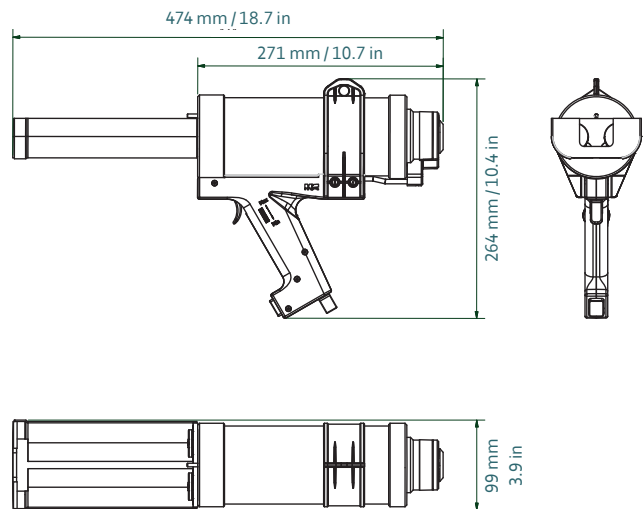

Part number	Article number	Packaging
DP2K 400-01-400-001	152309	1 per Box

MATCHING MIXPAC™ SIDE-BY-SIDE CARTRIDGES

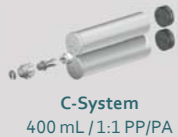

COMPATIBLE SIDE-BY-SIDE CARTRIDGES

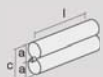

Plastic Cartridge
400 mL / 1:1 PP/PBT

1:1	mm	inch
l	185.0	7.28
a	Ø 45.0	Ø 1.77
c	93.0	3.66

CONVERSION KITS

MATCHING ACCESSORIES