

# TS459 XM

## 450 ML CARTRIDGE DISPENSER

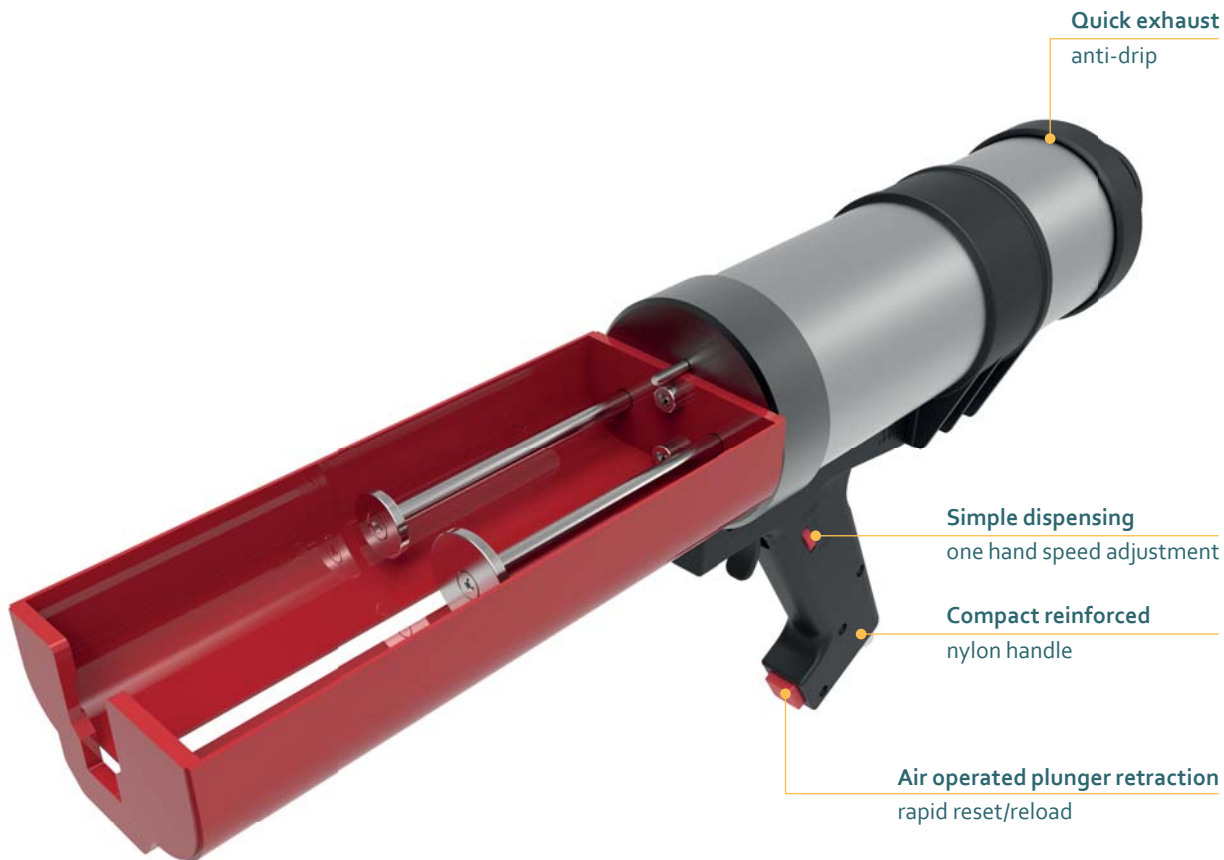

Model shown: TS459 XM 450 mL

### FEATURES

- Air operated plunger retraction
- One hand pressure adjustment
- Anti-drip function
- Long life technology
- Customization possible

### BENEFITS

- Quick cartridge exchange
- Simple dispensing speed adjustment
- Clean application
- Precise working
- Customer labelling

### APPLICATIONS



### PRODUCT BY RANGE



# THE TS459 XM 2-COMPONENT PNEUMATIC DISPENSERS ONE-HANDED PRESSURE ADJUSTMENT ALLOWS FOR SIMPLE EFFECTIVE OPERATION WHILE THE ANTI-DRIP FUNCTION MAKES FOR EASY AND CLEAN DISPENSING.

## SPECIFICATIONS

- Lightweight: 2.69 kg / 5.9 lbs
- Cartridge Holder Length: 218 mm / 8.6 in
- Maximum Thrust: 4.5 kN
- Maximum Pneumatic Pressure: 8 bar / 116 psi
- Air Consumption: 40 litres/min
- Handle Material: Reinforced Nylon
- Cartridge Holder Material: Aluminum
- Frame Material: Steel
- Cartridge Capacity: 450 mL (15.8 oz)
- Cartridge Ratio: 2:1
- Viscosity: Medium
- Standard Color: Black
- Customized versions on demand

## DIMENSIONS

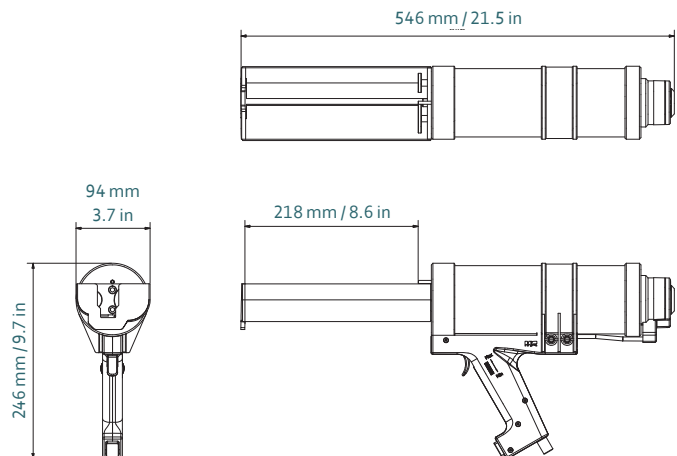

| Part number         | Article number | Packaging |
|---------------------|----------------|-----------|
| DP2K 450-02-400-101 | 152516         | 1 per Box |

## MATCHING MIXPAC™ SIDE-BY-SIDE CARTRIDGES



**J System**  
450 mL / 2:1 PP/PA

## COMPATIBLE CARTRIDGES

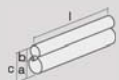

**Plastic Cartridge**  
450 mL / 2:1 PP

| 2:1 | mm     | inch   |
|-----|--------|--------|
| l   | 215.0  | 8.46   |
| a   | Ø 46.5 | Ø 1.83 |
| b   | Ø 33.2 | Ø 1.31 |
| c   | 86.0   | 3.39   |

## CONVERSION KITS

## MATCHING ACCESSORIES