

TS447 X-625

580 ML CARTRIDGE DISPENSER



Model shown: TS447 X-625 580 mL

FEATURES

- Quick exhaust
- Speed adjustment during operation
- Rapid reset/reload
- Customization possible

BENEFITS

- Prevents anti-drip
- Simple dispensing
- One hand pressure adjustment
- Customer labelling

APPLICATIONS



PRODUCT BY RANGE



TS447 X-625

THE TS447 X-625 2-COMPONENT PNEUMATIC DISPENSER IS DESIGNED FOR USE WITH HIGH VISCOSITY SEALANTS AND ADHESIVES. A ONE-HANDED PRESSURE ADJUSTMENT ALLOWS FOR RAPID RESET AND RELOAD.

SPECIFICATIONS

- Lightweight: 3.53 kg / 7.87 lbs
- Cartridge Holder Length: 269 mm / 10.6 in
- Maximum Thrust: 6.25 kN
- Maximum Pneumatic Pressure: 8 bar / 116 psi
- Air Consumption: 40 litres/min
- Handle Material: Reinforced Nylon
- Cartridge Holder Material: Aluminum
- Frame Material: Steel
- Cartridge Capacity: 580 mL (20.4 oz)
- Cartridge Ratio: 1:1
- Viscosity: High
- Standard Color: Black/Red
- Customized versions on demand

DIMENSIONS

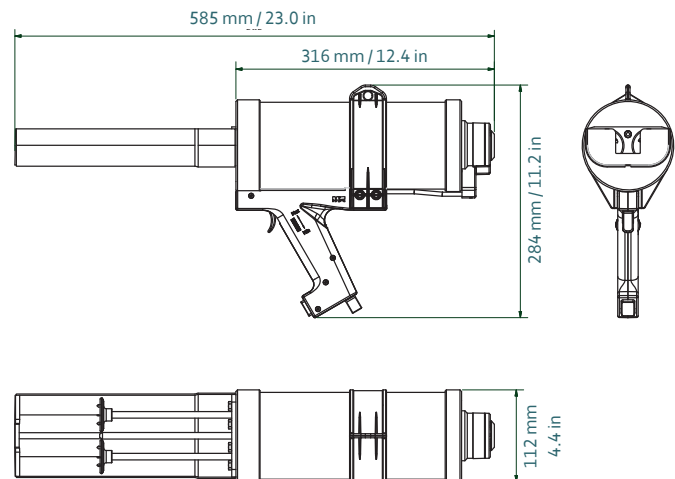

Part number	Article number	Packaging
DP2K 585-03-400-101	152387	1 per Box

MATCHING MIXPAC™ CARTRIDGES

COMPATIBLE SIDE-BY-SIDE CARTRIDGES

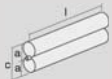

Aluminum Cartridge
580 mL / 1:1

1:1	mm	inch
l	238.0	9.37
a	Ø 47.0	Ø 1.8
c	98.0	3.8

CONVERSION KITS

MATCHING ACCESSORIES