

TS444 KX

365/385/585 ML CARTRIDGE DISPENSER

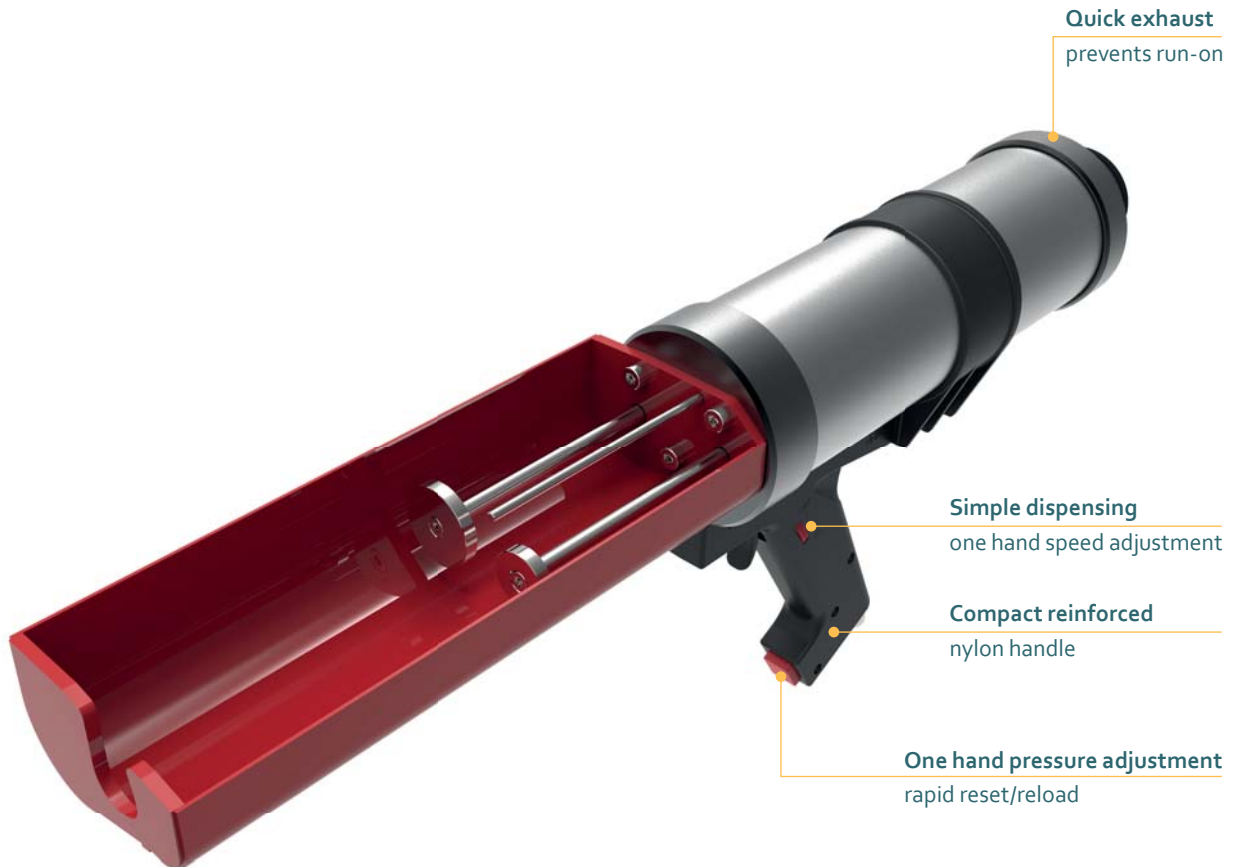

Model shown: TS444 KX 585 mL

FEATURES

- Quick exhaust
- Speed adjustment during operation
- Rapid reset/reload
- Customization possible

BENEFITS

- Prevents anti-drip
- Simple dispensing
- One hand pressure adjustment
- Customer labelling

APPLICATIONS



PRODUCT BY RANGE



TS444 KX

THE TS444 KX 2-COMPONENT PNEUMATIC DISPENSERS COMPACT REINFORCED NYLON HANDLE ALLOWS FOR SIMPLE EFFECTIVE OPERATION, WHILE THE QUICK EXHAUST VALVE PREVENTS MATERIAL ANTI-DRIP FOR EFFORTLESS DISPENSING.

SPECIFICATIONS

- Lightweight: 3.05 kg / 6.80 lbs
- Cartridge Holder Length: 278 mm / 11.0 in
- Maximum Thrust: 4 kN
- Maximum Pneumatic Pressure: 8 bar / 116 psi
- Air Consumption: 40 litres/min
- Handle Material: Reinforced Nylon
- Barrel Material: Aluminum
- Cartridge Holder Material: Steel
- Cartridge Capacity: 365 mL (12.8 oz), 385 mL (13.5 oz), 585 mL (20.6 oz)
- Cartridge Ratio: 3:1
- Viscosity: Medium
- Standard Color: Black/Red
- Customized versions on demand

DIMENSIONS

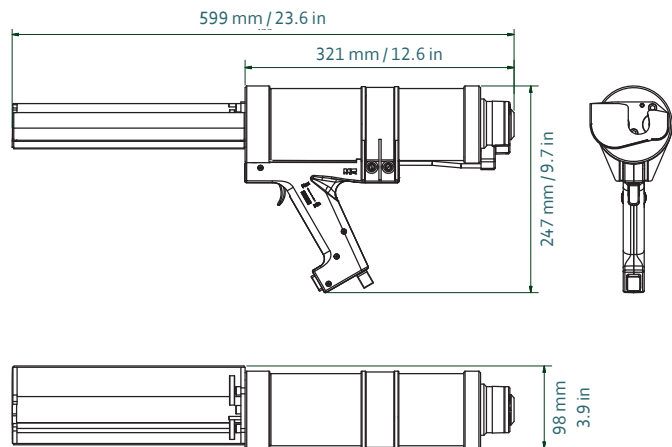

Part number	Article number	Packaging
DP2K 585-03-400-101	152487	1 per Box

MATCHING MIXPAC™ SIDE-BY-SIDE CARTRIDGES



J-System
365 mL / 3:1 PP



ecopaCC Cartridge
600 mL / 3:1

COMPATIBLE SIDE-BY-SIDE CARTRIDGES

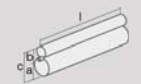

Plastic Cartridge
585 mL / 3:1

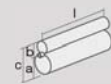

Plastic Cartridge
385 mL / 3:1 PP

3:1	mm	inch
l	244.0	9.61
a	Ø 54.4	Ø 2.14
b	Ø 32.6	Ø 1.28
c	90.0	3.54

3:1	mm	inch
l	171.0	6.73
a	Ø 54.4	Ø 2.14
b	Ø 32.6	Ø 1.28
c	90.0	3.54

CONVERSION KITS

MATCHING ACCESSORIES