

T16 X

310 ML CARTRIDGE DISPENSER

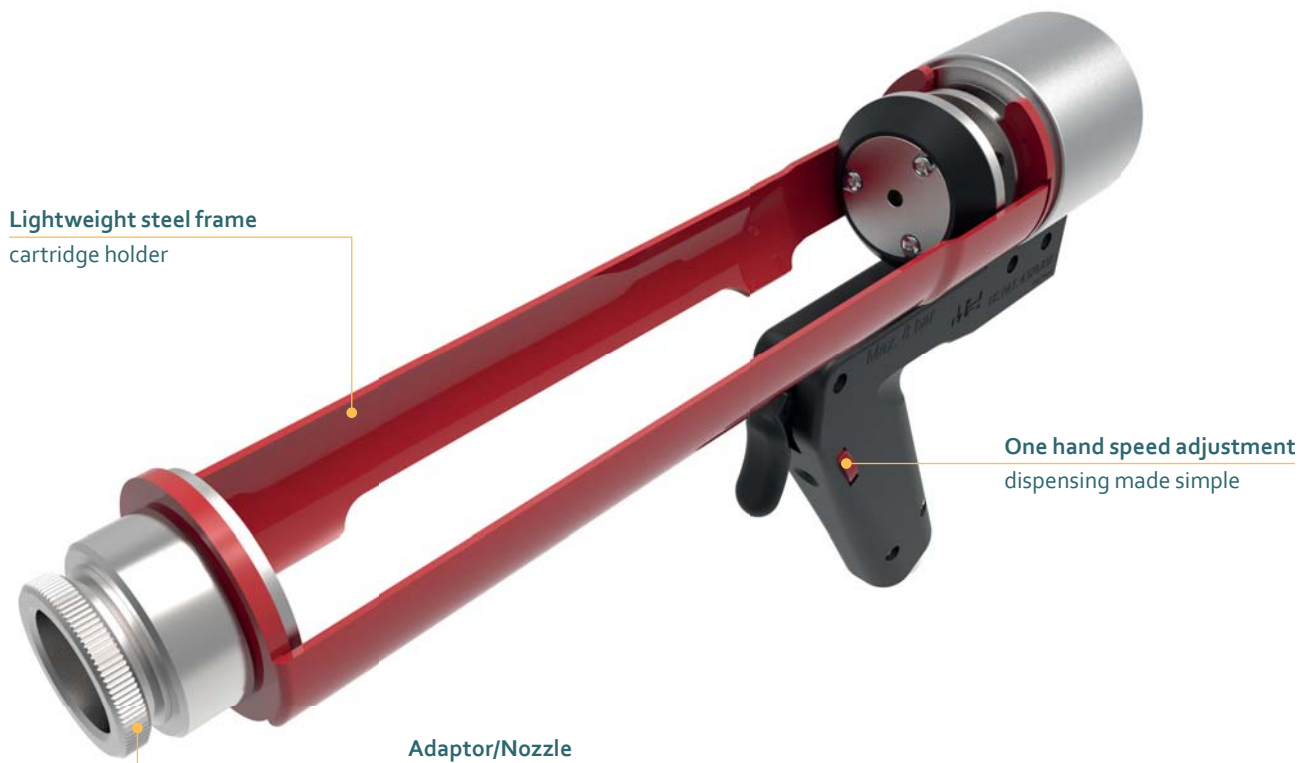

Model shown: T16 X 310 mL

FEATURES

- Reinforced nylon handle
- One hand pressure adjustment
- Operates without the use of a piston
- Forward air release
- Warranty up to 2 years

BENEFITS

- For comfortable use
- Easy simple dispensing
- Ideal for compact spaces
- Fast, reliable and easy handling
- Gives you long worry free performance

APPLICATIONS



PRODUCT BY RANGE



T16 X

THE T16 X 1-COMPONENT PNEUMATIC DISPENSER'S ONE-HANDED PRESSURE ADJUSTMENT AND 8 BAR (116 PSI) REGULATOR MAKES FOR EASY DISPENSING.

SPECIFICATIONS

- Lightweight: 0.88 kg / 1.94 lbs
- Frame Length: 228 mm / 9.0 in
- Maximum Thrust: 1.3 kN
- Maximum Pneumatic Pressure: 8 bar / 116 psi
- Air Consumption: 40 litres/min
- Handle Material: Reinforced Nylon
- Frame Material: Steel
- Tool Component Approvals: CE
- Cartridge Capacity: 310 mL
- Standard Color: Black/Red
- Nozzle Dimension: Ø 15.0 mm / 0.6 in
- Customized versions on demand

DIMENSIONS

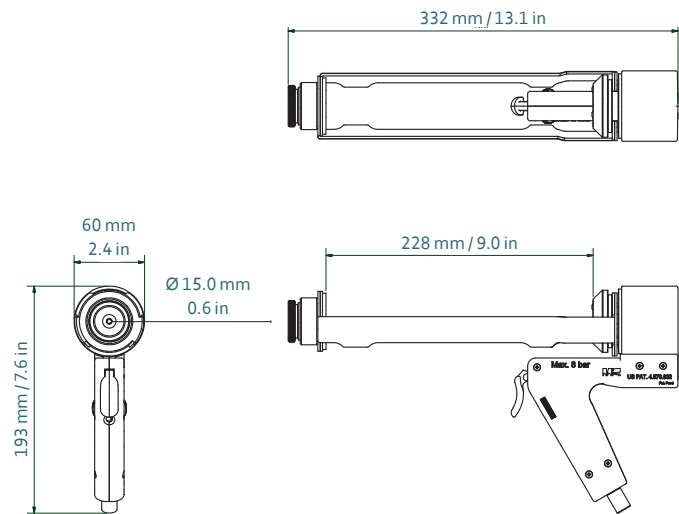

1 per box, 10 per master carton	Article number	Packaging
DP1K 310-ca-100-001	152510	1 per box, 10 per master carton
DP1K 310-ca-130-100	151775 (with Adaptor/Nozzle)	1 per box, 10 per master carton

MATCHING MIXPAC™ CARTRIDGES

COMPATIBLE CARTRIDGES

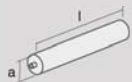

Plastic Cartridge
310 mL HPDE/PP/PA

	mm	inch
l	216.0	8.5
a	Ø 48.2	Ø 1.8

CONVERSION KITS

—

MATCHING ACCESSORIES

Yellow Nozzles on pages 40–41