

PPM 300X

375/450/600 ML CARTRIDGE DISPENSER

Epoxy coated steel frame
for efficient dispensing



Epoxy coated aluminum handle
ergonomically design for comfort

Minimum trigger pressure
for effortless use

Model shown: PPM 300X 600 mL

FEATURES

- High quality cast aluminum handle
- Epoxy coated steel frame support
- Sintered alloy catch plate
- Customization possible

BENEFITS

- For day long comfortable use
- For efficient dispensing
- Wear compensation device (WCD)
- Customer labelling

APPLICATIONS



PRODUCT BY RANGE

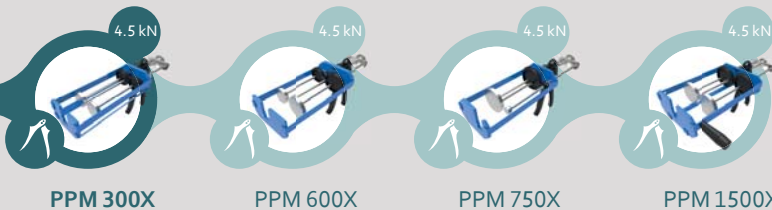

THE PPM 300X 2-COMPONENT MANUAL DISPENSER HAS A HIGH-POWERED 25:1 MECHANISM DESIGNED FOR USE WITH HIGH VISCOSITY SEALANTS AND ADHESIVES.

SPECIFICATIONS

- Lightweight: 1.7 kg / 3.7 lbs
- Frame Length: 232 mm / 9.1 in
- Maximum Thrust: 4.5 kN
- Handle Material: Epoxy Coated Aluminum
- Frame Material: Epoxy Coated Steel
- Tool Component Approvals: REACH
- Cartridge Capacity: 375 mL (12.7 oz), 450 mL (15.3 oz), 600 mL (20.3 oz)
- Cartridge Ratio: 1:1, 2:1, 4:1
- Mechanical Advantage Ratio: 25:1
- Viscosity: High
- Standard Color: Black/Blue
- Customized Versions: Yes

DIMENSIONS

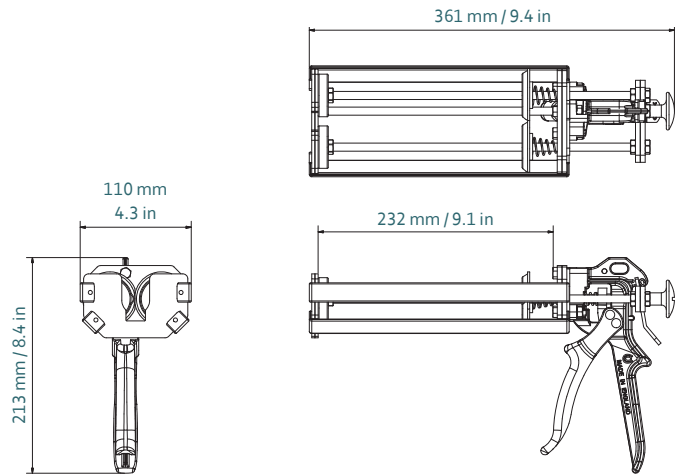

Part number	Article number	Packaging
DM2C 600-MR-r25-001	167327 (multi ratio)	10 per Box

MATCHING MIXPAC™ CARTRIDGES

COMPATIBLE SIDE-BY-SIDE CARTRIDGES

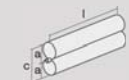

Plastic Cartridge
600 mL / 1:1 PP

1:1	mm	inch
l	217	8.54
a	Ø 48.0	Ø 1.89
c	95.5	3.76

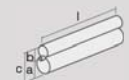

Plastic Cartridge
450 mL / 2:1 PP/PA

2:1	mm	inch
l	215.0	8.46
a	Ø 49.5	Ø 1.95
b	Ø 36.2	Ø 1.43
c	86.0	3.39

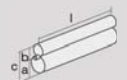

Plastic Cartridge
375 mL / 4:1 PP

4:1	mm	inch
l	215.0	8.46
a	Ø 49.3	Ø 1.94
b	Ø 26.7	Ø 1.05
c	76.0	2.99

CONVERSION KITS

Conversion kit included

MATCHING ACCESSORIES