

# H14 RS

## 310 ML CARTRIDGE DISPENSER



### FEATURES

- Anti-drip and trigger integrated brake release
- Ergonomic handle
- Steel frame cartridge holder
- Warranty up to 2 years

### BENEFITS

- Fast, reliable and easy handling
- For comfortable use
- Automatic cartridge positioning and fixation
- Gives you long worry free performance

### APPLICATIONS

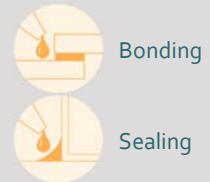

### PRODUCT BY RANGE



H14 RS

# THE H14 RS 1-COMPONENT MANUAL DISPENSER IS DESIGNED FOR USE WITH LOW TO MEDIUM VISCOSITY SEALANTS AND ADHESIVES THE ANTI-DRIP TRIGGER AND INTEGRATED BRAKE RELEASE DELIVERS FAST RELIABLE DISPENSING FOR ALL YOUR APPLICATIONS.

## SPECIFICATIONS

- Lightweight: 0.77 kg / 1.70 lbs
- Frame Length: 243 mm / 9.5 in
- Maximum Thrust: 1.5 kN (stroke 9.8 mm)
- Handle Material: Reinforced Nylon
- Frame Material: Steel
- Cartridge Capacity: 310 mL
- Mechanical Advantage Ratio: (12:1)
- Standard Color: Black/Red
- Nozzle Dimension: Ø 25.5 mm / 1.0 in
- Customized versions on demand

## DIMENSIONS

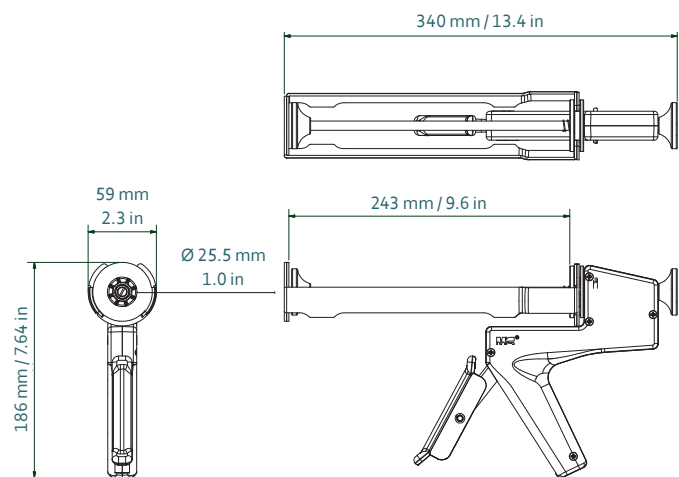

Part number	Article number	Packaging
DM1K 310-ca-r12-201	151723	Bulk packed with 10 units

## MATCHING MIXPAC™ CARTRIDGES



Peeler Cartridge

## COMPATIBLE CARTRIDGES

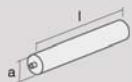

Plastic Cartridge  
310 mL HPDE/PP/PA

	mm	inch
l	216.0	8.5
a	Ø 48.2	Ø 1.8

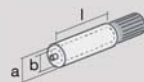

Plastic Cartridge  
150 mL 1:1, 2:1, 10:1 PP

	mm	inch
l	117	4.6
a	Ø 50.0	Ø 1.9
1:1 b	Ø 32.0	Ø 1.2
2:1 b	Ø 26.0	Ø 1.0
10:1 b	Ø 14.3	Ø 0.5

## CONVERSION KITS

–

## MATCHING ACCESSORIES

Nozzle extension / Twisty nozzle on pages 40–41