

# B998 M

## 825 ML CARTRIDGE DISPENSER

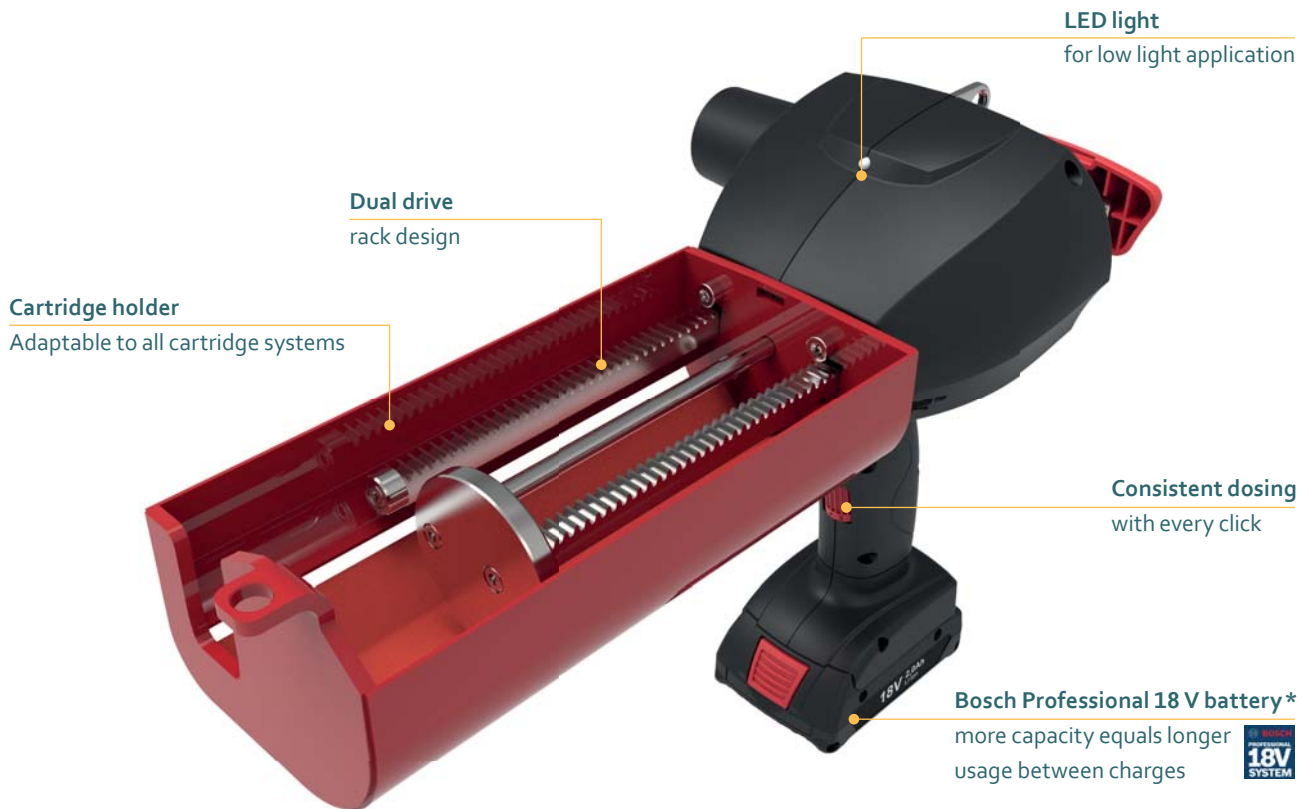

Model shown: B998 M 825 mL

### FEATURES

- Unique memory function
- Dual drive rack design
- Anti-drip function
- 18 V Li-ion high performance battery
- U-opening with cartridge snap fit
- Customization possible

### BENEFITS

- Consistent dosing with every click
- Reproduces quality of each adhesive
- Clean and efficient working
- Charge time: 65 min (100%)
- For easy insertion and removal of cartridges
- Customer labelling

### APPLICATIONS



### PRODUCT BY RANGE



B998 M

# THE B998 M 2-COMPONENT BATTERY DISPENSER DUAL DRIVE RACK AND UNIQUE MEMORY FUNCTION REPRODUCES CONSISTENT DOSING EVERY TIME, WHILE THE BOSCH PROFESSIONAL 18 V RE-CHARGEABLE BATTERY OFFERS LONGER USAGE BETWEEN CHARGES.

## SPECIFICATIONS

- Weight: 3.7 kg / 8.1 lbs
- Cartridge Holder Length: 232 mm / 9.1 in
- Maximum Thrust: 5 kN (5 mm/s)
- Voltage: 18 V
- Battery Capacity: 2.0 Ah
- Battery Charge Time: 65 min (100%)
- Battery Type: Li-ion
- Handle Material: Reinforced Nylon
- Cartridge Holder Material: Steel
- Cartridge Capacity: 825 mL (29 oz)
- Cartridge Ratio: 10:1
- Viscosity: Medium
- Standard Color: Black/Red
- Customized versions on demand

## DIMENSIONS

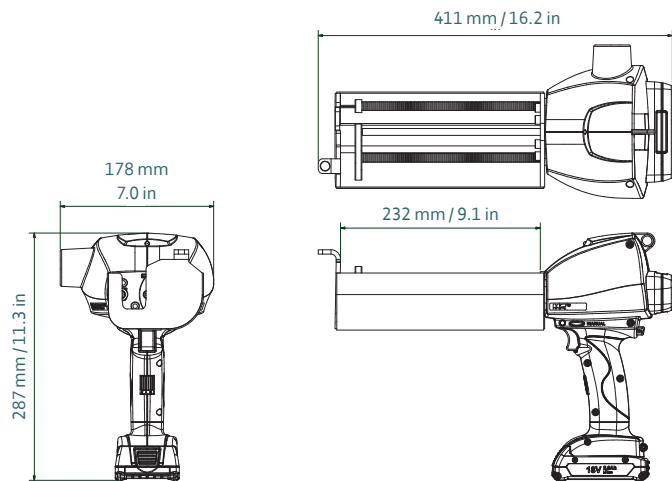

Part number	Article number	Packaging
DB2K 825-10-500-101	152614	1 per Box
DB2K 825-10-500-1US	152615 (US)	1 per Box

## MATCHING MIXPAC™ SIDE-BY-SIDE CARTRIDGES



**J-System**  
825 mL / 10:1 PA

## COMPATIBLE CARTRIDGES

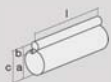

**Plastic Cartridge**  
825 mL / 10:1 PP

10:1	mm	inch
l	216.0	8.5
a	Ø 80.7	Ø 3.18
b	Ø 28.6	Ø 1.13
c	109.0	4.29

## CONVERSION KITS

—

## MATCHING ACCESSORIES

Batteries and chargers on pages 90.