

B988 M

600 ML CARTRIDGE DISPENSER

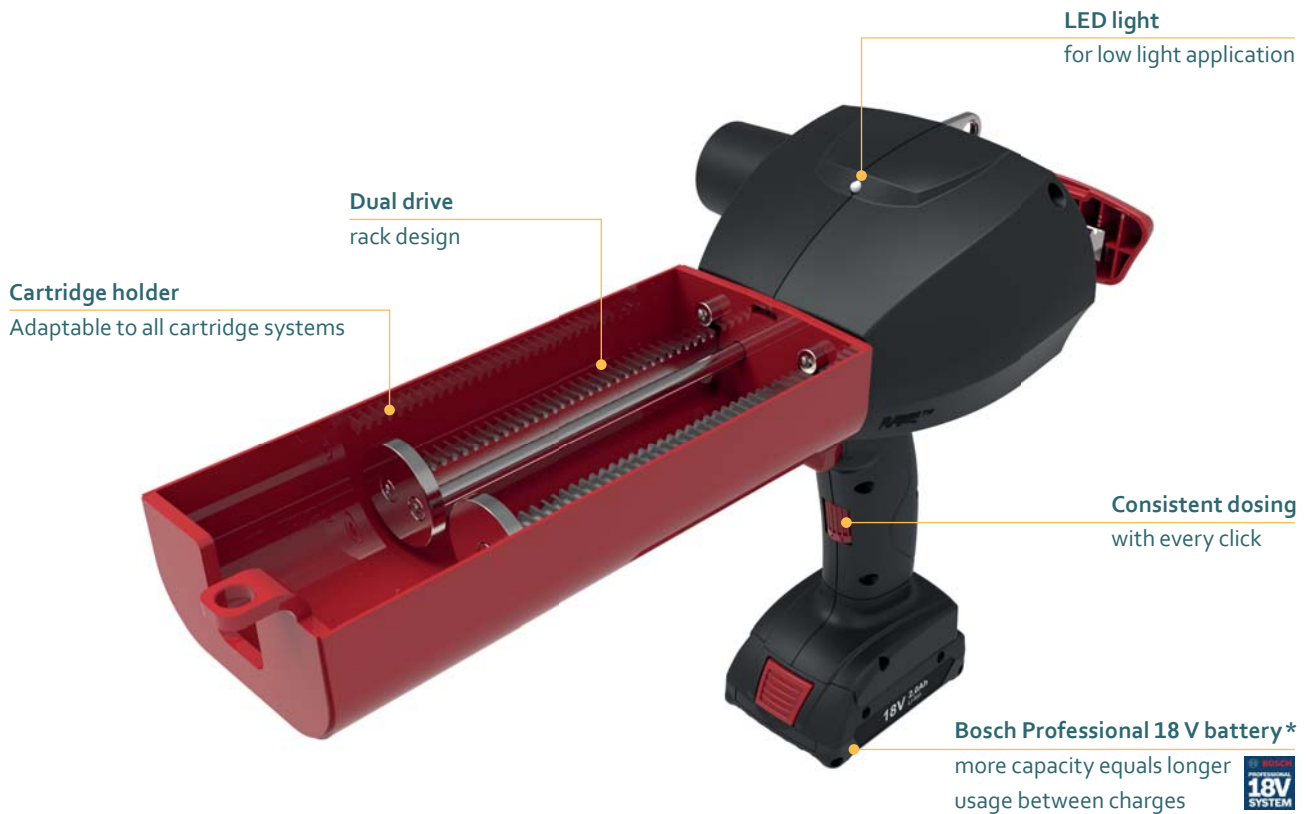

Model shown: B988 M 600 mL

FEATURES

- Unique memory function
- Dual drive rack design
- Anti-drip function
- 18 V Li-ion high performance battery
- U-opening with cartridge snap fit
- Customization possible

BENEFITS

- Consistent dosing with every click
- Reproduces quality of each adhesive
- Clean and efficient working
- Charge time: 65 min (100%)
- For easy insertion and removal of cartridges
- Customer labelling

APPLICATIONS



PRODUCT BY RANGE



B988 M

THE B988 M 2-COMPONENT BATTERY DISPENSER IS DESIGNED FOR USE WITH MEDIUM VISCOSITY SEALANTS AND ADHESIVES, WHILE THE BOSCH PROFESSIONAL 18 V RE-CHARGEABLE BATTERY OFFERS LONGER USAGE BETWEEN CHARGES.

SPECIFICATIONS

- Weight: 3.6 kg / 7.9 lbs
- Cartridge Holder Length: 234 mm / 9.2 in
- Maximum Thrust: 4.73 kN (5 mm/s)
- Voltage: 18 V
- Battery Capacity: 2.0 Ah
- Battery Charge Time: 65 min (100%)
- Battery Type: Li-ion
- Handle Material: Reinforced Nylon
- Cartridge Holder Material: Steel
- Cartridge Capacity: 600 mL (21.1 oz)
- Cartridge Ratio: 1:1
- Viscosity: Medium
- Standard Color: Black/Red
- Customized versions on demand

DIMENSIONS

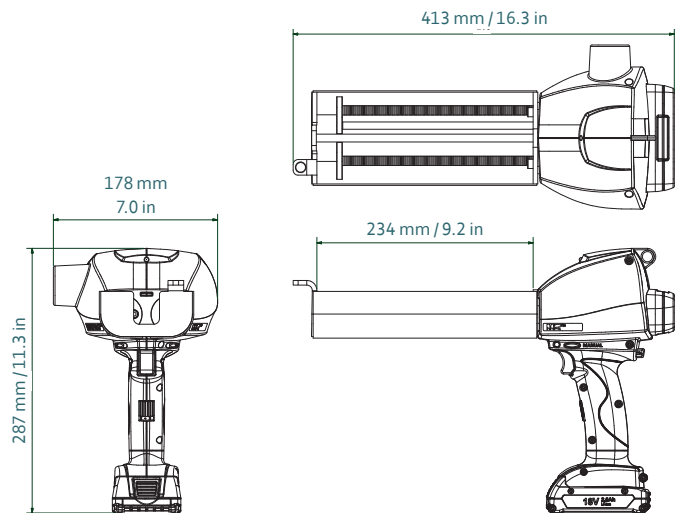

Part number	Article number	Packaging
DB2K 600-01-473-1US	152613 (US)	1 per Box
DB2K 600-01-473-101	152454	1 per Box

MATCHING MIXPAC™ SIDE-BY-SIDE CARTRIDGES



J-System
600 mL / 1:1 PP



ecopaCC
600 mL / 1:1 PP/PA

COMPATIBLE CARTRIDGES

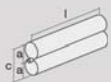

Plastic Cartridge
600 mL / 1:1 PP

1:1	mm	inch
l	217.0	8.54
a	∅ 48.0	∅ 1.89
c	95.5	3.76

CONVERSION KITS

–

MATCHING ACCESSORIES

Batteries and chargers on pages 90.