

# B985 M

## 380 ML CARTRIDGE DISPENSER

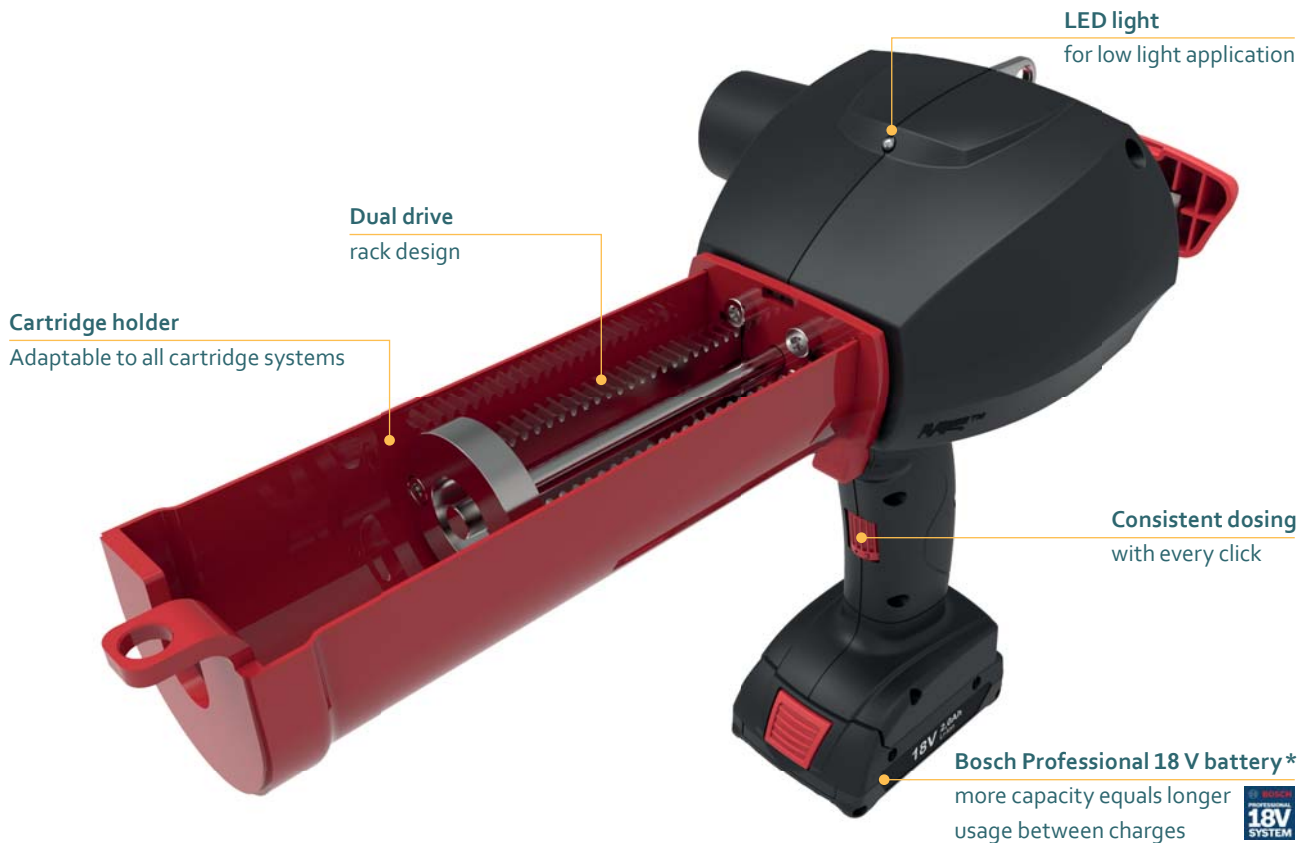

Model shown: B985 M 380 mL

### FEATURES

- Unique memory function
- Dual drive rack design
- Anti-drip function
- 18 V Li-ion high performance battery
- U-opening with cartridge snap fit
- Customization possible

### BENEFITS

- Consistent dosing with every click
- Reproduces quality of each adhesive
- Clean and efficient working
- Charge time: 65 min (100%)
- For easy insertion and removal of cartridges
- Customer labelling

### APPLICATIONS



### PRODUCT BY RANGE



B985 M

# THE B985 M 2-COMPONENT BATTERY DISPENSER IS DESIGNED FOR USE WITH LOW TO MEDIUM VISCOSITY SEALANTS AND ADHESIVES. THE DUAL DRIVE RACK AND UNIQUE MEMORY FUNCTION REPRODUCES CONSISTENT DOSING EVERY TIME.

## SPECIFICATIONS

- Weight: 3.3 kg / 7.3 lbs
- Cartridge Holder Length: 204 mm / 8.0 in
- Maximum Thrust: 2.75 kN (5 mm/s)
- Voltage: 18 V
- Battery Capacity: 2.0 Ah
- Battery Charge Time: 65 min (100%)
- Battery Type: Li-ion
- Handle Material: Reinforced Nylon
- Cartridge Holder Material: Steel
- Cartridge Capacity: 380 mL (13.4 oz)
- Cartridge Ratio: 10:1
- Viscosity: Low/Medium
- Standard Color: Black/Red
- Customized versions on demand

## DIMENSIONS

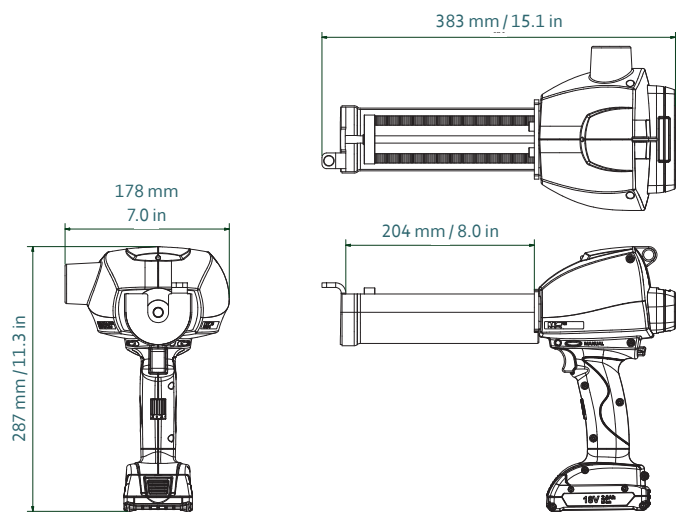

Part number	Article number	Packaging
DB2K 380-10-275-101	158093	1 per Box

## MATCHING MIXPAC™ COAXIAL CARTRIDGES



**Q-System**  
380 mL / 10:1 PA

## COMPATIBLE CARTRIDGES

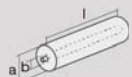

**Plastic Cartridge**  
380 mL / 10:1 PP/PA

10:1	mm	inch
l	183.0	7.2
a	Ø 63.0	Ø 2.5
b	Ø 18.0	Ø 0.71

## CONVERSION KITS

—

## MATCHING ACCESSORIES

Batteries and chargers on pages 90.