

AIRFLOW™ 3 CCA 380A

380 ML CARTRIDGE DISPENSER

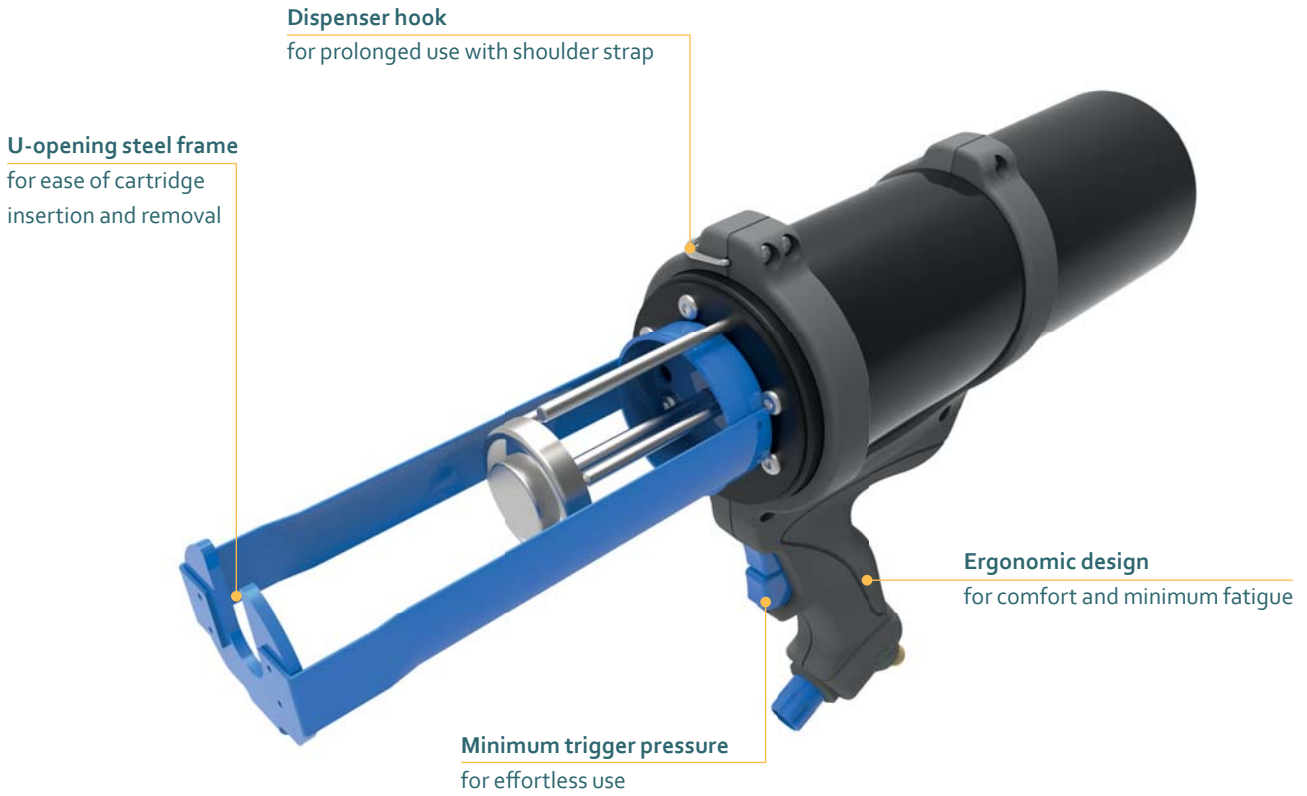

Model shown: AirFlow 3 CCA 380A 380 mL

FEATURES

- Air return as standard
- Minimum trigger pressure
- U-opening steel frame
- Quick exhaust valve
- Customization possible

BENEFITS

- Fast, accurate and effortless application
- For effortless use and minimum fatigue
- Ease of cartridge insertion and removal
- Prevents run-on
- Customer labelling

APPLICATIONS



PRODUCT BY RANGE



THE AIRFLOW 3 CCA 380A 2-COMPONENT PNEUMATIC DISPENSER IS DESIGNED FOR USE WITH MEDIUM TO HIGH VISCOSITY SEALANTS AND ADHESIVES. IT OFFERS AIR RETURN AS STANDARD FOR FAST, ACCURATE AND EFFORTLESS APPLICATION.

SPECIFICATIONS

- Weight: 2.5 kg / 5.5 lbs
- Frame Length: 178 mm / 7.0 in
- Maximum Thrust: 5 kN
- Maximum Pneumatic Pressure: 6.8 bar / 100 psi
- Air Consumption: 40 litres/min
- Handle Material: Glass filled nylon
- Frame Material: Steel
- Tool Component Approvals: CE, REACH
- Cartridge Capacity: 380 mL (13.4 oz)
- Cartridge Ratio: 1:1, 10:1
- Viscosity: Medium/High
- Standard Color: Black/Blue
- Customized versions on demand

DIMENSIONS

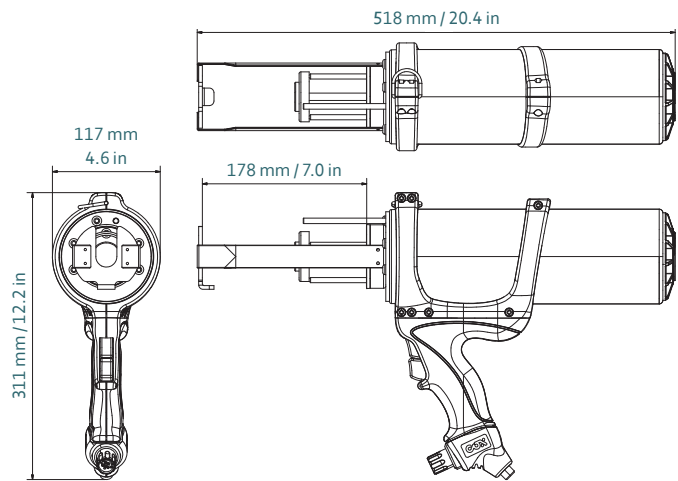

Part number	Article number	Packaging
DP2C 380-01-500-301	181394 / A380HP/1 (US) (1:1)	1 per Box
DP2C 380-10-500-301	181396 / A380HP/10 (US) (10:1)	1 per Box

MATCHING MIXPAC™ CARTRIDGES

COMPATIBLE COAXIAL CARTRIDGES

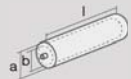

Plastic Cartridge
380 mL / 1:1 PP/PA

1:1	mm	inch
l	183.0	7.2
a	Ø 63.0	Ø 2.48
b	Ø 41.0	Ø 1.61

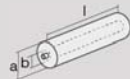

Plastic Cartridge
380 mL 5:1 / PP

	mm	inch
l	183.0	7.2
a	Ø 63.0	Ø 2.4
b	Ø 25.2	Ø 1.0

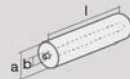

Plastic Cartridge
380 mL 10:1 / PP

	mm	inch
l	183.0	7.2
a	Ø 63.0	Ø 2.4
b	Ø 18.0	Ø 0.7

CONVERSION KITS

MATCHING ACCESSORIES