

# AIRFLOW™ 1 RBA 300B

## 600/620 ML CARTRIDGE DISPENSER



Model shown: AirFlow 1 RBA 300B 600 mL

### FEATURES

- Air return as standard
- Minimum trigger pressure
- U-opening steel frame
- Quick exhaust valve
- Customization possible

### BENEFITS

- Fast, accurate and effortless application
- For effortless use and minimum fatigue
- Ease of cartridge insertion and removal
- Prevents run-on
- Customer labelling

### APPLICATIONS



### PRODUCT BY RANGE



# THE AIRFLOW 1 RBA 300B 2-COMPONENT PNEUMATIC DISPENSER IS DESIGNED FOR USE WITH LOW TO MEDIUM VISCOSITY SEALANTS AND ADHESIVES FOR FAST, ACCURATE AND EFFORTLESS APPLICATION.

## SPECIFICATIONS

- Weight: 2.2 kg / 4.9 lbs
- Frame Length: 227 mm / 8.9 in
- Maximum Thrust: 2.2 kN
- Maximum Pneumatic Pressure: 6.8 bar / 100 psi
- Air Consumption: 40 litres/min
- Handle Material: Aluminum
- Frame Material: Steel
- Tool Component Approvals: CE, REACH
- Cartridge Capacity: 600 mL (21 oz), 620 mL (21.8 oz)
- Cartridge Ratio: 1:1
- Viscosity: Low/Medium
- Standard Color: Black/Blue
- Customized versions on demand

## DIMENSIONS

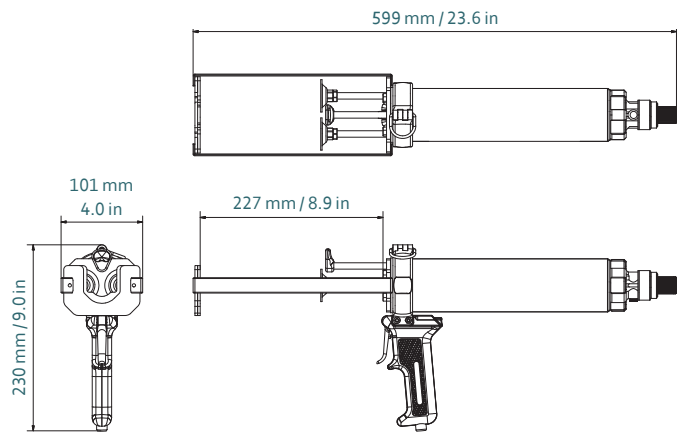

Part number	Article number	Packaging
DP2C 600-01-220-101	177871	1 per Box

## MATCHING MIXPAC™ SIDE-BY-SIDE CARTRIDGES

### COMPATIBLE SIDE-BY-SIDE CARTRIDGES

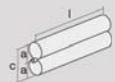

Plastic Cartridge  
600 mL / 1:1 PP



Plastic Cartridge  
620 mL / 1:1 PP

1:1	mm	inch
l	217.0	8.54
a	Ø 48.0	Ø 1.89
c	95.5	3.7

1:1	mm	inch
l	218.0	8.58
a	Ø 48.0	Ø 1.89
c	96.0	3.78

## CONVERSION KITS

## MATCHING ACCESSORIES